



Moisture Separator (P 23X)

Owner's Manual

Date of Issue 08/02/2022 TSOM 356B

Hodge Clemco Ltd

36 Orgreave Drive,
Handsworth,
Sheffield,
South Yorkshire,
S13 9NR,

Tel: 0114 254 1520

www.hodgeclemco.co.uk
sales@hodgeclemco.co.uk
totalcare@hodgeclemco.co.uk

MAINTENANCE INSPECTION CONTRACT

In response to numerous requests, we are now able to offer a Maintenance Inspection Contract for your Clemco Equipment.

These requests have been made by customers who appreciate the benefits of regular inspection/servicing on a planned basis. The remedial work that follows a breakdown or worse, the need for early equipment replacement due to accelerated wear may easily exceed the cost of a Maintenance Inspection Contract. If you would like further detail please contact our Customer Services Department on **0114 2548811**

A request for more information does not represent any form of commitment on your behalf, so can you afford to say 'NO' at this stage?

We look forward to hearing from you soon.

1.0 INTRODUCTION

WARNING: This unit is for use in industrial compressed air systems only and must not exceed its rated operating conditions. Maximum air pressure 17 bar (250 PSI), maximum temp 80 °C (175 °F).

2.0 INSTALLATION

- 2.1 Install as near as possible to the equipment being served. Ensure that the air follows the directional arrow on the body.
- 2.2 Do not restrict air flow with undersized pipe work.

3.0 OPERATION

- 3.1 Adjust the draincock to give a slight but constant bleed of air/water vapour.
- 3.2 Never allow the moisture level to reach the baffle.
- 3.3 Moisture levels may be read from the sight glass on the side of the bowl.

4.0 MAINTENANCE

WARNING: Ensure that the air supply has been isolated and that the air pressure is purged from the system before any maintenance is carried out.

WARNING: When cleaning components do not use solvents as they may cause component deterioration which can be dangerous. Use personal protective equipment when reverse cleaning with compressed air.

- 4.1 Inspect/clean the element weekly to avoid undesirable pressure drop across unit.
- 4.2 To remove the element for cleaning.
 - 4.2.1 Ensure air pressure has been purged from the system.
 - 4.2.2 Unscrew the bowl anti clockwise.
 - 4.2.3 Unscrew the baffle anti clockwise and remove the cintred bronze element, baffles and "O-ring.
 - 4.2.4 Clean components in detergent and water and reverse blow the element with compressed air.
 - 4.2.5 Replace cleaned/new components as per attached drawing.

P23X MOISTURE SEPARATOR: ARRANGEMENT DIAGRAMS + PARTS LIST

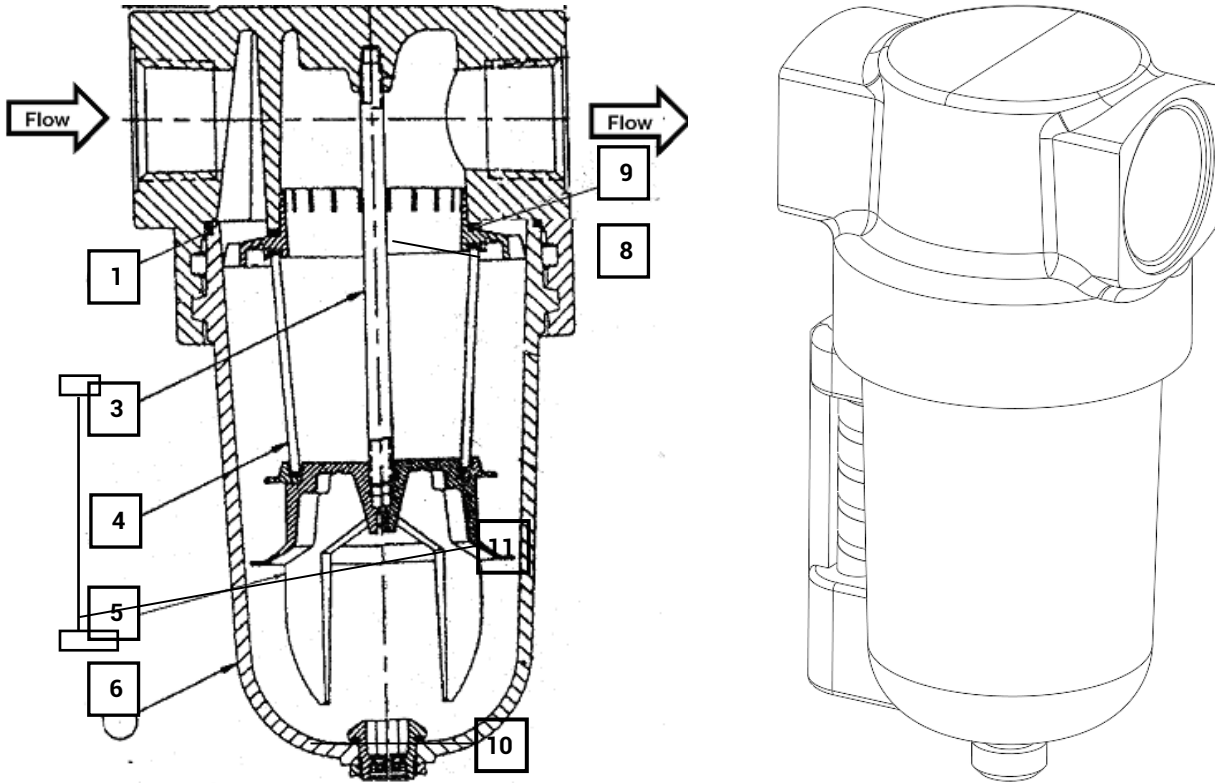

P23X MOISTURE SEPARATOR PARTS LIST		
No	DESCRIPTION	PART
4	FILTER ELEMENT	P23XA ELEMENT
1	'O' RING	P23XB (BOWL KIT)
3	BOWL	
4	MANUAL DRAIN	
5	SIGHT GLASS	P23XC (SIGHT GLASS KIT)
6	SIGHT GLASS KIT ONLY	
7	MANUAL DRAIN KIT ONLY	P23XD DRAIN KIT
8	LOUVRE	P23XE (BAFFLE KIT)
9	BAFFLE	
10	'O' RING	P23XF
11	ROD	